

# A Unified Control and Power Management in Hybrid Microgrids

**Haritha C<sup>1</sup>, Remya K V<sup>2</sup>**

<sup>1</sup>Student, Al-Ameen Engineering College, Kulappully, Kerala, India.

<sup>2</sup>Associate Professor, Al-Ameen Engineering College, Kulappully, Kerala, India.

Corresponding Author: harithachinnaswamy@gmail.com

**Abstract:** - Battery storage is usually employed in Photovoltaic (PV) system to mitigate the power fluctuations due to the characteristics of PV panels and solar irradiance. Control schemes for PV-battery systems must be able to stabilize the bus voltages as well as to control the power flows flexibly. This paper proposes a comprehensive control and power management system (CAPMS) with fuzzy logic for PV-battery-based hybrid microgrids with both AC and DC buses, for both grid connected and islanded modes. The proposed CAPMS with fuzzy logic is successful in regulating the DC and AC bus voltages and frequency stability, controlling the voltage and power of each unit flexibly, and balancing the power flows in the systems automatically under different operating circumstances, regardless of disturbances from switching operating modes, fluctuations of irradiance and temperature, and change of loads.

**Key Words:** — Solar PV System, Battery, Fuzzy Logic Controller, Control and Power Management System CAPMS.

## I. INTRODUCTION

Continually increasing demand for energy and concerns of environmental deterioration have been spurring electric power experts to find sustainable methods of power generation. Distributed generations (DG) in the form of renewable resources, such as solar energy, are believed to provide an effective solution to reduce the dependency on conventional power generation and to enhance the reliability and quality of power systems [1]. Photovoltaic (PV) power systems have become one of the most promising renewable generation technologies because of their attractive characteristics such as abundance of solar and clean energy. Rapid PV technology development and declining installation costs are also stimulating the increasing deployment of PV in power systems. However, due to the nature of solar energy and PV panels, instantaneous power output of a PV system depends largely on its operating environment, such as solar irradiance and surrounding temperature, resulting in constant fluctuations in the output power [2], [3]. Therefore, to maintain a reliable output power, battery storage systems are usually integrated with PV systems to address the variability issue.

A fuzzy control framework is a control scheme dependent on fuzzy rationale—a numerical framework that breaks down simple information esteems as far as intelligent factors that take on constant qualities somewhere in the range of 0 and 1, as opposed to old style or computerized rationale, which works on discrete estimations of either 1 or 0 (valid or bogus, separately).

## II. SYSTEM DESIGN

The system here will manage the batter system of Photovoltaic framework for backup in both island as well as grid mode, to achieve a stronger outline and betterment in voltage outcome. The schema will have controllers for PV array, Battery and Inverter which is been explained here to understand the design concepts of the system; MPPT controller will have a fuzzy logic controller connected to achieve an enhancement in voltage output. The diagram below depicts the system to show various blocks.

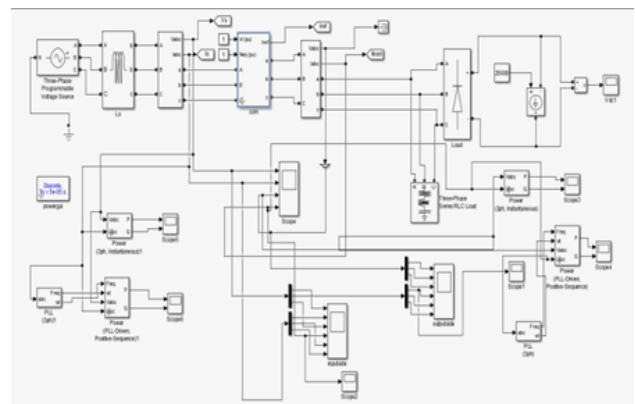

Figure.1. System Block Diagram

The following sections will explain the different parts of the system which has helped out to achieve the outcome.

### A. Fuzzy Logic Controller

A fuzzy control system consists of the following components:

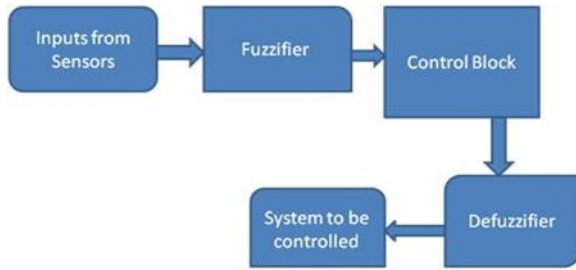

Figure.2. Fuzzy control system

A Fuzzifier which transforms the measured or the input variables in numerical forms into linguistic variables.

A Controller performs the fuzzy logic operation of assigning the outputs based on the linguistic information. It performs approximate reasoning based on the human way of interpretation to achieve control logic. The controller consists of the knowledge base and the inference engine. The knowledge base consists of the membership functions and the fuzzy rules, which are obtained by knowledge of the system operation according to the environment.

The Defuzzifier converts this fuzzy output to the required output to control the system.

### B. PV Array Controller

The PV cluster changes over sun based vitality into DC power, and is associated with the DC transport by means of a lift DC/DC converter.

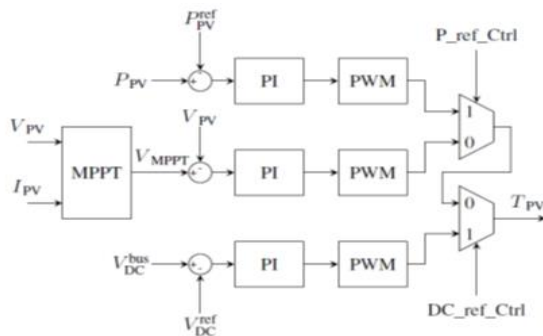

Figure.3. PV Array Controller [7]

Be that as it may, because of nonlinear qualities of PV boards and the stochastic variances of sun based irradiance, there is consistently a most extreme force point (MPP) for each particular working circumstance of a PV exhibit. Hence, most extreme force point following (MPPT) calculations are ordinarily executed in PV framework to remove the greatest force a PV cluster can give [28]. The proposed CAPMS utilizes one of the most mainstream techniques, the Incremental Conductance MPPT, which gives a reference voltage  $V_{MPPT}$  that the PV exhibit will track to produce the greatest force under different activity conditions (various blends of irradiance and temperature). There are three potential control plans for the PV cluster: MPPT control, power-reference control, and DC transport voltage control, contingent upon the circumstance of the PV-battery framework [2], [7].

### C. Battery Controller

Being an energy buffer, batter bank is compulsory in PV systems aimed at power harmonizing.

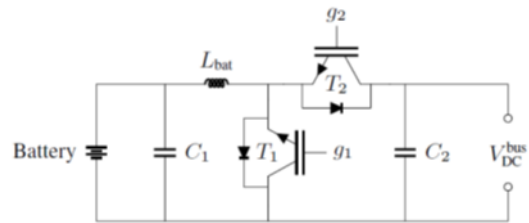

Figure.4. Bidirectional DC/DC Converter for Battery Bank

The battery bank of this coordination is allied to the DC bus, as presented in the diagram above, and is meticulous by a bidirectional DC/DC converter which encompassed two switches,  $T_1$  and  $T_2$ , that regulate the charging/ discharging procedure [7].

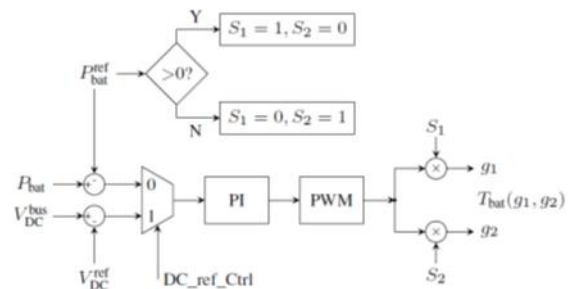

Figure.5. Battery charging/discharging controller [7]



Furthermore, CAPMS with fuzzy ensures a reliable power supply to the system when PV power fluctuates due to unstable irradiance or when the PV array is shut down due to faults. DC and AC buses are under full control by the CAPMS in both grid-connected and islanded modes, providing a stable voltage environment for electrical loads even during transitions between these two modes. This also allows additional loads to access the system without extra converters, reducing operation and control costs.

#### REFERENCES

- [1]. Zhehan Yi, Student Member, IEEE, Wanxin Dong, and Amir H. Etemadi, Member, IEEE, 2016.
- [2]. S. Kolesnik and A. Kuperman, "On the equivalence of major variable step-size MPPT algorithms," *IEEE J. Photovolt.*, vol. 6, no. 2, pp. 590–594, March 2016.
- [3]. Shayanfar, H.A. and Mokhtarpour, A. (2010) Management, Control and Automation of Power Quality Improvement. In: Eberhard, Ed., *Power Quality Book*, In-Tech, Croatia, 127-152.
- [4]. Hannan, M.A. and Mohamed, A. (2005) PSCAD/EMTDC Simulation of Unified Series-Shunt Compensator for Power Quality Improvement. *IEEE Transaction on Power Delivery*, 20, 1650-1656.
- [5]. T. A. Nguyen, X. Qiu, J. D. G. II, M. L. Crow, and A. C. Elmore, "Performance characterization for photovoltaic-vanadium redox battery microgrid systems," *IEEE Trans. Sustain. Energy*, vol. 5, no. 4, pp. 1379–1388, Oct 2014.
- [6]. Y. Rifonneau, S. Bacha, F. Barruel, and S. Ploix, "Optimal power flow management for grid connected PV systems with batteries," *IEEE Trans. Sustain. Energy*, vol. 2, no. 3, pp. 309–320, July 2011.
- [7]. Z. Yi, W. Dong and A. H. Etemadi, "A Unified Control and Power Management Scheme for PV-Battery-Based Hybrid Microgrids for Both Grid-Connected and Islanded Modes," *IEEE Transaction On Smart Grid*, 2016.