

## Design and fabrication of Oil Collector

**S H Pawar<sup>1</sup>, Shukla Amit Kumar<sup>2</sup>, Ahire Vishu<sup>2</sup>, Patil Yashodhan<sup>2</sup>, Patil Mayuresh<sup>2</sup>**

<sup>1</sup>Professor, Mechanical Department, BVCOE&RI, Nashik, Maharashtra, India.

<sup>2</sup>Student, Mechanical Department, BVCOE&RI, Nashik, Maharashtra, India.

Corresponding Author: amitshukla2609@yahoo.com

**Abstract:** - World has witnessed big oil spillage accidents into ocean and made huge impact to the environment. Apart this, sometimes Oil is getting spillage through being the results of chronic and careless habits in the use of oil industries and oil products. Offshore drilling & production operations and spills or leaks from ships or tankers are typically contributing less than 8% of the total whereas routine maintenance of ships (nearly 20%), onshore air pollution & hydrocarbon particles (about 13%) and natural seepage from the sea floor (over 8%). This has caused ever lasting damage to aquatic life. To separate the mixed oil from the water, industries wide various type of oil skimmers is getting used. Herewith, the objective of this project is to design and conduct efficiency studies of belt type oil skimmer by using various materialized belts. The belts absorb the oil from water which can be scooped out and collect into a vessel by providing piping arrangements.

**Key Words:** — *Oil spillage, offshore Drilling& production, Aquatic life, Oil skimmer.*

### I. INTRODUCTION

Pollution is a major area of concern in the modern era. The main reason of water pollution throughout the globe is oil and oil spills. Therefore, our aim is to control this type of pollution by designing equipment which separates oil from water. Hence, proper collection, disposition and storage of oil are necessary.

Many countries have made stringent safety norms for waste water disposal contained with oils mainly typically from petrochemical and process industries so that such industries are equipped with such kind of oil skimmers/Skimmers to separate the oils from disposal water. There are various methods are used for collecting the oil from water. Different types of machines are used for oil collection purpose.

The collection of spilled oil is performed by means of special vessels called oil skimmers/Skimmer. The ultimate aim of any recovery operation is to collect as much oil as is reasonably and economically possible.

A skimmer is defined as any mechanical device designed for the removal of oil (or oil/water mixture) from the surface of water without altering the water physical and/or chemical characteristics. The principles for skimmers' operation are based on the fluidity properties of oil and oil/water mixture, density differences between oil or oil/water mixtures, and water or differences in adhesion to materials.

These technologies are commonly used for oil spill remediation but are also commonly found in industrial applications such as removing oil from machine tool coolant and removing oil from aqueous parts washers. They are often required to remove oils, grease and fats prior to further treatment for environmental discharge compliance. By removing the top layer of oils, water stagnation, smell and unsightly surface scum can be reduced;

Placed before an oily water treatment system may give greater oil separation efficiency for improved waste water quality. It should be noted that all oil skimmers will pick up a percentage of water with the oil which will need to be decanted to obtain concentrated oil.

### II. BODY

#### A. Types of oil Skimmers

##### 1. Oleophilic type oil skimmers:

Oleophilic skimmers recover oil based on the properties of specific materials, which have greater affinity for oil than for water. There exist numerous types of oleophilic skimmers and they are therefore divided into subgroups such as disc skimmers, drum skimmers, rope mop skimmers, belt skimmers, and brush skimmers. Regardless of the type of skimmer, the principle behind the technique used is the same

for all oleophilic skimmers. The skimming head, i.e. the part with the oleophilic surface, is rotated or pulled through the oil slick and the oil is then scraped or squeezed off and the oil removed into a sump to be pumped or sucked away.

Oleophilic skimmers usually achieve the highest ratio of recovered oil in relation to entrained water, also referred to as the recovery efficiency, compared to other skimmer types. Oleophilic skimmers reach their highest efficiency when handling medium viscosity oils (between 100 – 2000 cSt). Diesel, kerosene and other low viscosity oil products generally do not adhere to the oleophilic surface in sufficiently thick layers to attain high recovery rates. Higher viscosity oils such as heavy bunker oil on the other hand, can prove to be difficult to remove due to its tendency to form large clumps in the water, which are too heavy and compact to be skimmed. Comparatively, oil-water emulsions can be almost impossible to recover with oleophilic skimmers, due to the fact that emulsions are nearly non-adhesive.

Oleophilic materials are often made of some form of polymer even though metal surfaces have shown to be effective. Furthermore, studies show that discs and drums with grooved surfaces result in higher recovery rates than smooth surfaces.

Types of oleophilic oil are as follows:

- Rope Type Oil Skimmer
- Belt Type Oil Skimmer
- Drum Type Oil Skimmer
- Floating Tube Skimmer

**Rope Type Oil Skimmer:**



Fig. 1.1.1 Rope Type Oil skimmer

This type of oil Skimmer use rope made up of suitable material for separation of oil. Rope mop skimmers use ropes floating on the surface of the water to retrieve the oil. Rope mop skimmers are large units and require the use of a crane during the entire operation for launching from either a vessel or shore. The oil is recovered by the ropes, which are then wrung releasing the oil into a collection tank either on board the vessel or on the shore. This skimmer type is not sensitive to waves but is normally only used for single sweep operations. Vertical rope mop skimmers are most suited for lighter oil types as very little water is collected during recovery. Debris or ice will not affect the skimming operation. Rope mop skimmers are ideal for shallow water conditions, as the rope requires minimal water to float. Furthermore, Rope mops are ideal in trash-laden environments since the trash falls off the ropes as they come up to the wringer unit.

**Belt Type Oil Skimmer:**



Fig 1.1.2 Belt Type Oil Skimmers

Belt skimmers are large and are therefore often mounted on a barge or on a specially constructed vessel. These skimmers have a high recovery efficiency and good recovery rate, but are specialized products and can be complicated to operate, which requires heavy equipment and specially trained personnel. However, a fixed position mounted belt skimmer requires an initial tuning but can then operate independently.

**Drum Type Oil Skimmer:**



Fig 1.1.3 Drum Type Oil skimmer

The oil floating on the surface of water clings on to the cylindrical drum due to adhesion property. Drum skimmers are driven by air or hydraulics and are therefore often considered for use in hazardous areas and environments. Drum skimmers are versatile skimmers and can handle various types of oils ranging from light oils such as diesel to heavier oils such as crude oil.

**Floating Tube Skimmer:**



Fig 1.1.4 Floating Tube Skimmer

The tube keeps skimming as water level fluctuates. Oil adheres to outside surface of tube. Tube oil skimmers are designed to ensure consistent, even operation, regardless of the application. They continuously remove oil from the surface of the water using a closed loop tube that floats on the surface of the water, attracting the floating oil or grease. Oil adheres to the outside of closed loop tube, which is

continuously driven across the separator's surface and through a set of scrapers that remove the oil, which is then drained into a collection tank. They are flexible and versatile, easy to install, need low maintenance, not affected by level fluctuation, working parts are out of the liquid, less costly to use.

**2. Non oleophilic oil Skimmers:**

**Suction Skimmer:**



Fig 1.1.5 Suction Skimmer

Suction skimmers such as vacuum skimmers represent the simplest skimmer design in terms of operational theory, whereby oil is recovered by air suction systems directly from the water surface. The simplest type of vacuum skimmer uses a hose directly connected to a vacuum truck, which can easily be employed in harbors or rivers. Due to the sensitivity to waves, vacuum skimmers are often restricted to use in harbors and calm waters. Furthermore, suction skimmers are ideally suited for recovery of oil on or near the shoreline due to the widespread availability of vacuum systems. Nonetheless, the undifferentiating nature of the suction device may result in high proportions of water also being collected.

**Weir Skimmer:**

Weir skimmers refer to a skimming devices using gravitational force to drain oil from the water surface. Weir skimmers are floating units where the edge of the weir is positioned just below the upper slick surface or at the interface between the floating oil and water, hence allowing oil to flow over the weir edge into a collecting sump. The oil is then pumped to storage tanks. Weir skimmers are normally launched from vessels using a crane and the weir can either be remote controlled by compressed air or self-adjusting. Weir skimmers are one of the most commonly used skimmer type due to its simple construction.





Fig 1.1.6 Weir Skimmer

Weir skimmers are however prone to be jammed or clogged due to floating debris, and although swell alone does not interfere with skimming operation, weir skimmers are very sensitive to steep waves.

Due to importance of oil Skimmer/skimmer, our project aims at designing of belt type oil Skimmer. The belt type oil Skimmer contains various parts like belt, bearings, motor, pulleys, shaft, and collecting tank. Our project aims at proper selection and design of the dimensions of the components and accurate assembly of the same.

We have selected belt type oil skimmer due to the following reasons:

- It can collect relatively dry oil. (i.e. oil which contains less than 50% water)
- Belt can be easily mounted on the pulleys.
- Overall equipment is compact in size.
- The belt type oil Skimmer is easy to clean.
- Capital cost involved is comparatively low.

Belt is made of materials like polymer, steel, rubber, polyurethane, etc. The material is selected on basis of its polar & non-polar properties. Water consists of polar molecules as H<sup>+</sup> and OH<sup>-</sup> whereas oil doesn't have any polar molecules hence it reacts as non-polar element. Polar & non-polar molecules attract towards their respective elements and bond with it. Moreover, to these, Oil is lighter in density as compared to water, so oil floats on it. Hence, water and oil form a separate layer in the reservoir. Belt material will be selected in such a manner so it can react as a non-polar element and oil gets attracted towards it.

### **Working principle of belt type oil skimmer:**

Oil skimmers are pieces of equipment that remove oil floating on the surface of a fluid. In general, oil skimmers work because they are made of materials to which oil is more likely to stick than the fluid it is floating on. At the same time, the fluid has very little attraction to oil skimmers. The density of water is more than oil; so the oil rises on the top of the water. The viscosity of oil is more than water. Motor drives the belt which is held firmly between the two pulleys. The belt is made to pass through oil-water mixture. Hence, oil sticks on the surface of the driving component of Skimmer, i.e. belt, tube, drum, etc.

By using scraper mechanism, the oil can be separated easily. (The belt is made of oleophilic material. The meaning of oleophilic is: 'having affinity for oils rather than water.' The different oleophilic materials are polymer, rubber, polyurethane, steel, etc.)

Belt oil skimmers utilize a belt of stainless steel. This belt is lowered into the liquid that needs to be cleaned. The belt then passes through special wiper blades, which remove the oil from both sides of the liquid as it passes through.

Oil skimmers have all that is necessary to remove oil from a liquid. In some cases, however, oil skimmers may be used to pre-treat a fluid. In this case, the oil skimmers remove as much of the oil as possible before more expensive and time-consuming measures are employed. Pre-treating the fluid with oil skimmers reduces the overall cost of cleaning the liquid.

### **3. Components of oil Skimmer**

The following are components of oil skimmer:

- Belt
- Motor
- Pulleys
- Scraper (Wiper)
- Bearings
- Oil Tank

#### **Belt:**

The oil which is present in water or other fluid, sticks to the belt surface which is then separated accordingly. Materials used for belt are Polymers, Steels, Polyurethane, and Rubber etc.

Polyurethane material is chosen because of the following reasons. Polyurethane is a polymer composed of organic units joined by carbamate (urethane) links.

Polyurethanes are used in manufacturing of seals, gaskets, belts, skateboard wheels, etc. It has high durability, it can resist harsh environmental factors like abrasion, heat, solvents, oils, acids.

#### **Motor:**

Motor provides driving force for pulley and belt. There are different types of motors. They are DC Motors, AC Motors, Synchronous motors, Induction motors. AC motors are driven by Alternating current (AC). The AC motor commonly consists of two basic parts: An outside stationary stator having coils supplied with alternating current to produce a rotating magnetic field.

There is also an inside rotor attached to the output shaft producing a secondary rotating magnetic field. The rotating magnetic field may be produced by permanent magnet, reluctance saliency, or AC electrical windings. When an AC motor is in steady state rotation, the magnetic field of the rotor and the stator rotates with little or no slippage. The magnetic forces between the rotor and the stator poles creates an average torque capable of driving load at a rated speed. AC motors offer some advantages over DC motors. Some of the advantages are, reduced power line disturbances, lower power demand on start, controlled acceleration. Hence, we selected AC motor for our project.

#### **Pulleys:**

Pulleys are used for gripping the belt and to keep it in proper tension. Pulley is a wheel with grooved rim around which cord passes, which acts to change the direction of force applied to the chord and is used to raise weights. It is a wheel on an axle or shaft that is designed to support moment. The different types of pulleys are flat pulleys, grooved pulleys, V grooved pulleys, etc. They are made up of different materials like plastics, wood, metals, non-ferrous materials, etc. For reducing overall cost and weight of the project, we used pulleys made up of fibre reinforced plastic.

#### **Scraper (Wiper):**

Its function is to remove the oil that sticks or clings to the surface of belt. The contact between belt and scraper enables the removal of oil. It is made up of mild steel. An angle of 30 degrees is provided for inclination. A small hole is drilled for removal of oil through nozzle.

#### **Bearings:**

They are used to support the two shafts and also function as dead weight. Bearing is a machine element that constraints relative motion to only the desired motion and reduce friction between moving parts. There are 6 types of bearings; Plain bearings, Journal bearings, rolling element bearing, fluid bearing, magnetic bearing, Flexure bearing, ball bearing. We have selected Pedestal bearing for support to mount on the frame of the project.

#### **Oil Tank:**

Oil tank contains the mixture of oil and water. For demonstration purpose, the oil skimmer will separate the oil present in oil-water mixture in the oil tank. The oil tank is estimated to be of dimensions as 450mm x 325mm x 175mm.

#### **4. Working of Oil Skimmer:**

As we know, the density of water is greater than that of oil. Hence, oil floats on the surface of water. Due to this, oil is clearly visible on the surface. Viscosity plays a vital role in the working of the equipment. The viscosity of oil is greater and hence oil easily clings on the surface of the belt of the oil Skimmer.

A motor is present which drives the shaft. The shaft has a pulley on it. The belt is wound over the pulley. There are two pulleys present. The motor drives the shaft and eventually the belt rotates between the two pulleys. The belt is passed through the mixture of water and oil.

The oil sticks to the surface of moving belt and is thereby separated from water. Later on, the belt comes in contact with the wiper (scraper) that is provided in the equipment. Due to the contact between belt and the scraper blade, the oil falls down in the collecting tray or tank and can be reused, if necessary.

This ensures proper removal of oil and separation from the water source. Hence, the working is quite simple and easy to understand. Due to prolonged usage, the belt can wear out. It can be easily replaced.

#### **Advantages of belt type oil Skimmer:**

- Low capital cost.
- Minimum labour requirement.
- Can collect relatively dry oil (<50% water).
- Belt is easily replaceable.

- The weight & cost of belt is less.

#### **Limitations of belt type oil Skimmer:**

- Oil collected can contain some amount of water.
- There is friction of belt due to regular operation.
- Oil leakage occurs mostly in industrial areas or coastal areas; hence the use of project is limited.
- Efficiency is affected by debris.
- Slow oil skim rate.
- Friction of belt due to regular operation.

#### **Applications:**

- Used in navy: This oil separator can be used in navy to collect the oil in sea if any oil spill occurs.
- Used in industries: This oil separator can be used in industries where oil is a major material used and leakage of oil occurs regularly.
- Marine applications: Offshore plants like ONGC.
- Oil collecting stations like Bombay High.

#### **5. Problem statement:**

Oil leakage in industries and reservoirs need to be controlled efficiently. There is wastage of oil as well as harm to the environment due to this leakage. There is a need to separate this oil that causes pollution.

Hence, our project aims at efficient separation and collection of oil in domestic and industrial locations. Belt type oil skimmer is used in our project work.

The work of the project includes design of following components:

- Shaft
- Bearings
- Pulleys (Driver, Driven)
- Belt

The benefits after completion of the project will be efficient, portable equipment that can be used in concerned locations.

#### **6. Objectives**

The following objectives are taken into consideration:

- Design of oil Skimmer components.
- Fabrication of parts like tank, frame.
- The machine should be portable.
- Cost of manufacturing of machine must be within reasonable range.

#### **7. Scope**

Appropriate design of all the components required for the project was carried out followed by detailed drawings on CATIA software. The components were manufactured in workshop as per requirements. Some components were procured from external agencies. After proper assembly, the project was tested.

#### **8. Methodology**

This section describes all the processes that are taken into account while fulfillment of this project. The process is followed in the sequence as shown:

##### **Design:**

The very first step in manufacturing any machine or any component is design. The first step in the project was selection of the various components. The capacity of motor was in the range of 0.25 HP-5HP. This capacity was selected on basis of application area. For small scale applications like industrial wastes or domestic use, 0.5 HP motor is selected.

Design of shaft is based on A.S.M.E. codes. It is based on maximum shear stress theory. The diameter of shaft is calculated along with allowable stresses values.

After the diameter of shaft is calculated, selection of bearing was done from manufacturer's catalogue. Values of radial and axial loads were calculated and dimensions of bearings were selected.

The length of belt, angle of contact of belt is calculated by referring Reference books and research papers. Further, the diameter of pulley was calculated.

##### **Computer aided drawing:**

The detailed design calculations were carried out theoretically. The help of textbooks and reference books was

taken. CATIA software was used to sketch the components and give us a visual idea about the project.

### ***Manufacturing:***

In this step, the final draft of the design is used to manufacture different components of the machine. Components such as Motor, collecting tank, belt are standard and hence we imported these parts from external agencies. Other components such as shafts, pulleys, scraper (wiper) were selected accordingly on the basis of designed dimensions. The fabrication work was carried out in the workshop where the frame, oil outlet from tank, support plate for motor were made by welding and use of nuts and bolts. The final assembly was completed successfully.

### **III. ORGANIZATION OF DISSERTATION**

Chapter 1 Introduction: Environment preservation is the need of the hour. There are different types of pollution. As an engineer the main aim along with innovation and technological development is recycling and nature preservation. Hence to reduce water pollution by spillage of oil we decided to design and manufacture a device which would reuse and utilize the oil. Also, this would keep the water clean. Therefore, we studied different types of oil skimmers and decided to research on Belt type oil skimmer. The theory that we searched on internet and reference books was studied thoroughly.

Working principle: This is the most important part of any mechanical device. To understand the use of different components, working principle was studied. Videos relating to working of belt type oil skimmer were viewed. Then, the major components were analyzed. The detailed theory of components was studied.

Working of Model: This chapter deals with the detailed working of each part of the project. In depth analysis of each part is carried out. The detail such as power supply, capacity of motor, dimensions of motor, Type of coupling to be used, types of gearbox used was analyzed. The different layouts that are usually used were observed and best suitable layout according to the needs was decided.

Chapter 2 Review of Literature: Various research papers on this topic were downloaded and studied. The different information regarding belt type oil skimmers was collected. Some research paper showed design calculations of various components necessary for assembly and working of project. Other research papers provided information on oil spills in

different regions of the world. The different methods of removing oil were discussed. In this way detailed information was read and noted down.

Chapter 3 Design of oil skimmer: Firstly, the textbook and reference books containing formulae of gearbox, motor, shaft, pulley, Bearings and other components were studied. The design of shaft was based on ASME codes. The capacity of motor was decided on the basis of required output of oil to be separated. There are different types of gear boxes i.e. spur helical gear box, helical helical pair, worm and worm gear box etc. worm and worm gear type gear box was selected because it is light in weight and compact in size. Bearings were selected on manufacturer's catalogue. Fiber reinforced plastic pulleys were selected.

The modeling of the components to be used was completed on CATIA software. Firstly, components like pulley, bearing, belt, motor, nuts and bolts were modeled. Secondly, components that had to be fabricated were drawn on basis of dimensions of the above components. Parts like frame, tank, shaft, scraper (wiper) were modeled.

Chapter 4 Fabrication of Oil Skimmer: In this chapter, we have given step by step procedure describing fabrication of our project. The process sheets for major components like shaft, frame, Tank are included in this chapter. Also, the time required to complete each process is given. The images provided in this chapter clearly indicate the step by step approach undertaken while fabricating the project in the workshop. The cost analysis along with the bill of materials is included in this chapter.

Chapter 5 Experimental validation and result: In this chapter, the result were taken. Oil of particular densities were taken. The setup was run for a specific time period and rate of oil removed (in lph) was observed. The future scope is included in this section as every setup has some limitations and scope for improvement and further additions.

### **IV. REVIEW OF LITERATURE**

Literature review is gathered to understand the topic in depth. We carried out search of the different research papers and assembled the information together. Various sources helped us to understand the topic more effectively and the following research papers were reviewed:

Prof. M. Patel [1] in her paper "Design and Efficiency Comparison of Various Belt Type Oil Skimmers" calculated the various dimensions regarding belt type oil Skimmer. The

design calculations carried out by her included length of flat belt, angle of contact of belt, tension in belt, torque of belt, linear velocity of belt, angle of lap, efficiency of belt, power transmitted by belt, selection of belt material, etc. She made the use of induction motor for the working of oil Skimmer. She calculated the dimensions of tank frame and supporting plate. She made the following observations for selection of belt material:

The belt should be made of such a material which can easily lift/carry the oil above head and pour it over the blade. The oil lifts through belt by having the its materials following inherent properties:

Belt material is selected according to its polar & non-polar properties. Water consists of polar molecules as H<sup>+</sup> and OH<sup>-</sup> whereas oil doesn't have any polar molecules hence it reacts as non-polar element. Polar & non-polar molecules attract towards their respective elements and bond with it. Moreover, to these, Oil is lighter in density as compare to water so always oil floats on it. Hence water and oil form a separate layer in the reservoir. Belt material has been selected in such a manner so it can react as a non-polar element and oil gets attract toward it and get stick on it which permit us to easily lift the oil through belt. Here we are selecting the belt materials of polymers (non-polar). like., Cotton, Steel, Rubber, Polyurethane, Oleophilic, etc.

Adhesive property of oil is greater than water so we select such a material for the belt having adhesive property greater than water and having close to oil, hence it can easily absorbs oil over the belt which ultimately gets separate from water. Since water having poor adhesive property, it doesn't stick much to belt and remains in the reservoir.

During operation, belt is getting wear due to friction and subsequently reduction of its life. Oleophilic material offers less wearing property as compare to polyurethane so ultimately Oleophilic belt is choose to use in Oil skimmer. She concluded the following:

“In this project, we enforced to highlight the function of oil skimmer, its various design aspects and performance. All the results of experimental studies indicate that slight design improvement of typical oil skimmers towards to include additional belt shaft and use of belt with steel material instead of rope; significantly improve the oil recovery efficiency and also its structure became simpler. As practical overview of different oil spillage cleanup method, this paper has illustrated several limitations of these methods and current oil spill technology. Further extensive research & testing can improve

the existing techniques and equipment to have better control for oil recovery exercise.”

Sadek Z. Kassab [2] wrote a research paper titled “Empirical correlations for the performance of belt skimmer operating under environmental dynamic conditions” in 2010. He stated: The present study is predicting, by deducing empirical correlations, the effect of varying the operating and the environmental parameters on the performance of belt skimmer. The belt linear speed, belt inclination angle and oil film thickness are the operating parameters. The current speed and the wave height are the environmental parameters. The oil recovery rate, ORR and the oil recovery efficiency, the most important parameters displayed the performance of the belt skimmer, are predicted by empirical correlations as function of these operating and environment parameters.

Mechanical devices for the removal of oil from the surface of water are known as 'skimmers'. Skimmers may be static or dynamic. A static skimmer is a recovery device, which is not being moved through the water, and no water and oil is moving past it. A dynamic skimmer is a unit, which is moved through the water or it may be fixed and the water and oil is moving by. Most skimmers are meant to be dynamic. The scientific work concerned with the different types of skimmers is limited in the literature. Kassab et al. (2007) studied the effect of varying the operating parameters on the performance of beltskimmer.

The belt linear speed, belt inclination angle and oil film thickness are the operating parameters considered in their study. Kassab et al. (2007) found that the oil recovery rate increases with the increase of the oil film thickness and the decrease of belt inclination angle. The effect of varying the belt linear speed on the oil recovery rate depends on the range of this speed. Meanwhile, the oil recovery efficiency increases by increasing the belt inclination angle and/or oil film thickness and/or decreasing belt linear speed. In addition, it is important to point out that Kassab et al. (2007) compared their experimental data with both the theoretical results of Shoier (1998) and the empirical results obtained using static skimmer data, Hammoud and Khalil (2000). This comparison revealed that the three sets of results have the same trend and there was good agreement, on average, between the experimental and the empirical results. Kassab et al. (2006) studied the effect of varying the environmental parameters on the performance of belt skimmer. The current speed and the wave height were the environmental parameters considered in their study. The results are presented for the oil recovery rate, ORR, as well as the oil recovery efficiency, ORE. Within the operating range of the considered parameters, their results show that the oil recovery rate decreases by increasing the current speed. The



oil recovery efficiency decreases by increasing the current speed and wave height.

On the other hand, Kassab et al. (2006) concluded that "The comparison between the results obtained using static belt skimmer (zero current speed and wave height) and the results obtained using dynamic belt skimmer reveals that their trends are different with the increase of belt linear speed." This fact initiated the effort towards modifying the existing empirical correlations or finding new ones taking into consideration the effects of the dynamic parameters, such as current speed and wave height. For the best knowledge of the present author, there is no empirical formulas existed in the open literature taking into consideration these dynamic effects.

Consequently, one aim of the present study is to achieve this goal.

Arturo A. Keller and Kristin Clark [3] in "Oil Recovery with Novel Skimmer Surfaces under Cold Climate Conditions" studied about properties of oil like density, viscosity, surface tension, etc. They performed various tests on the oil and water mixture. They developed groove type oil Skimmer. The tests were conducted at the Cold Regions Research and Engineering Laboratory (CRREL). The objective of this project was to perform a comprehensive analysis of the adhesion between oil or ice-in-oil mixtures and various surface patterns and materials, under cold climate conditions. This knowledge was then applied to improve existing mechanical response equipment so that it can be applied efficiently under these conditions. The novel recovery surfaces that proved to increase the recovery efficiency of a drum skimmer up to two times in warm waters were also successful in cold climate conditions. materials were conducted, to determine contact angle and amount of oil adhered at subfreezing conditions, with and without ice. It became clear that the physicochemical property that would be most significantly influence by cold climate conditions would be viscosity, and that the presence of ice would also have an important effect on viscosity, although to a varying degree depending on the initial oil viscosity. Neoprene was the best material surface, of those tested here, for adhering oil even under oil/ice conditions.

Based on the results of the laboratory tests at subfreezing conditions, we selected materials and surface patterns with the highest oil recovery potential under cold climate conditions, and performed field scale oil spill recovery tests with three different oils at the US. Army Corps of Engineers Cold Regions Research and Engineering Laboratory (CRREL), located in Hanover, NH. This provided valuable information about the correlation between the laboratory tests and full

scale experiments. It also demonstrated the potential of the skimmer modifications under conditions similar to response operations. The field tests were very successful, with high rates of oil recovery under cold climates, with and without ice present. However, the presence of ice does decrease the overall rate of oil recovery to some extent.

These studies served to advance the goals of the Coastal Response Research Center, the Prince William Sound Oil Spill Recovery Institute, and the Minerals Management Service by providing important information for the improvement of cleanup of oil spills in cold climates. The outcome of this project advanced our understanding of the adhesion of oil and oil emulsions (water containing and ice-containing) to recovery surface material under cold climate conditions. This research will facilitate selection of materials and surface configurations that result in significantly higher recovery rates of oil spills in cold and ice-infested waters. This will ultimately lead to a faster oil spill cleanup and greater protection of natural resources.

The objective of this project was to perform a comprehensive analysis of the adhesion processes between oil or ice-in-oil mixtures and various surface patterns and materials that are being used or proposed for use in oil skimmers, under cold climate conditions. This knowledge can be used to develop mechanical response equipment that can be efficiently used under these conditions. The three most relevant physicochemical properties for understanding oil recovery from surface water spills are density, viscosity, surface tension.

Andrea AGRUSTA, Filippo Bianco, Luigi Perrella, Giuseppe Perrella, Igor Zotti [4] at 'International Conference of Transport Science' presented a research paper named "Oil skimmers for coastal waters and open sea cleaning" presented an idea of a skimmer equipped with a funnel-shaped conveyor, supported by floats, drawn inside of the spill to be cleaned or self-propelled in it with its own drive and/or remote-controlled guide. This device has been named FL.O.C. (Flexible Oil Skimmer) and has the primary function to intercept and collect the share of surface water, on which float pollutants and debris to be removed. It can be classified as a weir skimmer, which is very flexible and used with light and heavy oils. It can be equipped with different ancillaries, such as a separator and a collection tank, and used autonomously or have tugs or support ships to transfer the collected oil, to be treated on board.

It is scalable in different sizes so to be used for land reclamation in areas with limited space up to catastrophic theaters in reduced dimensions; it is equipped with inflatable

floats, so that they can be stored in a tank of reduced overall dimensions. They stated:

The collection of spilled oil is performed by means of special vessels called oil skimmers. The ultimate aim of any recovery operation is to collect as much oil as is reasonably and economically possible. These vessels can be specially-built for the purpose or fitted with equipment to be used for intervention. The intervention can be very different depending on the theater of action; the open sea or ocean, rivers, harbors or confined areas; in the presence or absence of winds or currents, etc. Another factor which characterizes the operation is the quantity of oil that should be recovered. It can range from a few hundred kilograms (for example in port areas contaminated by routine operations) to the millions of tones (for example in the episode of the Gulf of Mexico). A successful recovery system must overcome the interrelated problems of encountering significant quantities of oil and its subsequent containment, concentration, recovery, pumping and storage. The recovery and pumping elements of the overall operation are frequently combined in a skimmer. All skimmers are designed to recovery oil in preference to water, but designs vary considerably according to the intended use, for example in sea, in sheltered waters or onshore and for this reason the units used in these types of interventions are therefore deep sea, ocean, coastal, or port.

Furthermore, the unit responsible for the collection can be autonomous in operations, i.e. it can circumscribe, collect and transport the residue to the ground by itself; or it may require other units and vessels in order to perform, in which case it operates in groups of units.

The oleophilic skimmers employ materials that have an affinity for oil in preference to water. The oil adheres to the surface of the material, commonly taking the shape of a disk, drum, belt, brush or rope-mop which, as they rotate, lift the oil from the water surface. Alternately to oleophilic skimmers there are the non-oleophilic skimmers, which can be classified as suction skimmers, weir skimmers or other skimmer type.

The solution presented for the oil skimmer to be used in coastal waters and ports is the result of studies, research and experiments on models carried out at the University and Research Area of Trieste. The solutions presented take into consideration the needs required to have a unit that is available quickly, easily manageable and easy to use, adaptable to complementary activities, such as cleaning of beaches and small harbors. The obtained product, still in the experimental phase, should respond to the requirements and be available in short time.

Anne Louise Brown, Michelle Mary Hanley and Nathaniel M. Stanton [5] in "Surface Oil Skimmer- Sea Grant Depository" designed side-mounted oil recovery system which is adapted to different boats. In event of small oil spills, SOS (Surface Oil Skimmer) is a very accessible solution for fishermen and local authorities involved in cleanup. The paper described about development of system including technical analysis of each major component. Tests were done which verified integrity of the SOS system.

Tushar Pathare, Mauli Zagade, Rohan Pawar, Priteshkumar Patil, Prof. A.S. Patil [6] presented a research paper named "Endless Belt Type Oil Skimmer" at International Journal of Recent Research in Civil and Mechanical Engineering (IJRRRCME). They designed a belt type oil skimmer by using a DC42 series motor with combination of gearbox. They used gearbox for reduction of speed of motor. They proposed some great future advancement like use of solar panels for driving the DC motor, using oil resistant belt, etc. The abstract of the project is: "Pollution has created lot of problems in industries. By removing the oil from waste water, it becomes free of oil pollutions. Oil skimmers are commonly found in three types: weir, oleophilic and non-oleophilic. Oleophilic skimmers are distinguished not by their operation but by the component used to collect the oil (rope, disk, belt or drum). It can remove even a thin floating film of oil from the water. This is mainly due to the "oleophilic material" used in the belt. A free floating endless belt oil skimmer was developed as means of recovering spilled oil from surface water. The skimmer utilizes a unique high efficiency belt which is driven by motor. By removing oil we can preprocess water for other use. This can avoid water wastage and control pollution due to oil spillage. In current world scenario most of the oil from the industries goes wasted into ponds, rivers and sea. So, national and international environmental norms are getting strict day by day. It is economical to manufacture a low cost machine to meet these norms."

DC42 series motors are Dc motors (outsourced) that are used in combination with some Mechtex gearheads. Depending on the application, output speed, load applied etc the type of gear head can be selected. Case hardened steel gears are used due to the high torque generated by these motors. First pair of gears can be helical to damp the noise. All bearings are permanently lubricated and therefore require no maintenance. Gear box is mounted on motor shaft for reduction in speed of motor. one end of gear box shaft is attached to motor shaft and other end is attached to the coupling. From all the calculation done it is seen that the required torque is 5.7324 N-m with weight of 1 Kg. The whole assembly of the motor with gear box is mounted in the molded box. It reduces speed from 2400 to 30 rpm by using four stage reduction gear box. In this four

stage the first stage is helical gear because the speed reduction is maximum so compare to other gear it is effective. And other three stages are the spur gear. Belt is made up of polymer material. It is endless type which has width of 154 mm. The material is so selected to stick oil to belt. It is mounted on the aluminum pulley. Length of open belt is 1800 mm. It is immersed in liquid up to 100 mm. Belt material has good oil removal rate and it can withstand high temperature up to 180 F hence we have selected polyurethane belt. Tension to the belt is given by lower pulley with dead weight. Most hydrocarbons have a lower specific gravity than water. Without agitation, oil separates from the water and floats to the surface. These oils are known as LNAPL's, Light Non-Aqueous Phase Liquid.

Oils (and other compounds) that sink in water have a higher specific gravity and are known as DNAPL's, Dense Non-Aqueous Phase Liquid.

Victoria Broje and Arturo A Keller [7] in "Improved mechanical oil spill recovery using an optimized geometry for the skimmer surface" researched to improve the efficiency of mechanical oil spill equipment by optimizing the geometry of the oleophilic skimmer recovery surface. They developed a pattern of series of triangular shaped grooves in direction of rotation of recovery unit.

Saara Hanninan and Juka Sassi [8] who work in Research Council of Norway in their "Acute Oil Spills in Arctic Waters" gave detailed information about the different type of oil skimmers used in the Arctic region. They stated: Oil recovery bucket skimmer was developed by SYKE in the 1990's for oil collecting from water surface and from onshore and it has been successfully utilized in both applications. The skimmer adhere the oil to the stiff, rotating brushes and as the drum rotates, the oil is swept from the brushes and the oil enters the bucket. A screw pump transfers the oil to recovery tanks. The oil recovery bucket collected successfully oil among ice in March 2006 in Estonian waters. Oil recovery bucket skimmers exist in three different sizes. The smallest device has sweeping width of 60 cm, the medium size's sweeping width is 1.6 m and the largest has sweeping width of 3 meters. The two larger buckets can be connecting to and operated by hydraulic crane or hydraulic excavator. The mechanical recovery part of the JIP on Oil in Ice –program included laboratory scale testing of five different skimmer options. As the result two skimmers, i.e. Ro-Clean Desmi Helix 1000 and Lamor LRB 150, were selected for field test trials in Barents Sea in May 2008. The test results indicated that the Helix 1000 skimmer works best in low ice concentrations up to 40–50% and might also have a potential for application alongside larger ice floes. Cohesive oil slicks

can be effectively drawn into the brushes provided that the drum speed is not too high. The results indicated that the Polar Bear skimmer can be effective in collecting flowing oil when positioned in oil of varying slick thickness (several mm to several cm) among ice pieces. Cohesive oil slicks can be effectively drawn into the brushes provided that the drum speed is not too high (5–10 rpm in these tests) and the sump lip remains above the sea surface. The skimmer works best in the presence of low concentrations of smaller ice pieces and slush ice (< 50–70 %) and might also have the potential for application alongside larger ice floes. (Singsaas, *et al.*, 2010) The Framo skimmer, as presented in the trials described in the reference (Singsaas *et al.*, 2008), requires more development on basic skimmer components to ensure that a fully functional machine is developed. The bristles and the scrapers must be improved and modifications to buoyancy are required. The triangular shape together with its thrusters was a successful combination and allowed the skimmer to move very well in ice. It was concluded that a skimmer with thrusters that utilizes brush drum technology would be a highly useful mechanical recovery device for oil spills in ice infestations.

The Framo skimmer is expected to ultimately have the potential to effectively recover oil in small ice concentrations up to 70%. According to the background material provided by the developing company temperature, pumping capability, stiffness or viscosity of the recovering material does not decrease the performance of the system, and even recovery of dispersed and emulsified materials, debris, blue-green algae and contaminated ice is possible. Due to the operation principle the recovered material must be floating or otherwise close to the surface. In addition to skimmers, also a method for recover oil under ice and ice vibrating unit have been offered as mechanical oil combating options. Oil Whale concept presents a novel oil recovery method that has been developed in Finland. It utilizes the difference of gravity and viscosity of the recovered materials, and floating or otherwise material close to the surface can be collected. Similar technological applications have also been employed in the oil recovery actions at the Gulf of Mexico in 2010. The winterization of the method needs to be accomplished before

the applicability of the system to arctic conditions can be verified. The new Finnish multipurpose vessel to be mobilized in 2011 will be equipped with innovative oil recovery technology. The movable drum skimmer units in addition to brush belts and oil booms will offer improved response preparedness also in ice-covered waters compared to the present situation in the Gulf of Finland.

Peter Grill and Fredrik Linde [9] in their thesis "Oil Skimming Business Potential and Strategic Options Facing a

Marginalised Business Segment at Sandvik Process Systems” stated The purpose of this thesis is to study the oil skimming market and evaluate what drives company competitiveness and market attractiveness. Throughout the thesis, the total oil skimming market has been divided into an industrial market and an offshore market as these applications have entirely different requirements. However, the skimming market in general is underdeveloped and the long lifetime of the equipment has a negative impact on the market development speed. It is therefore characterized by a fragmented body of competitors and diverging pricing. Instead of price being an order-winning aspect, recovery rate and ability to pick up a large variety of oils has been found to be important. In this inductive, and interpretivistic case study, a model for market analysis of an underdeveloped market is developed and applied to Sandvik Process Systems’ oil skimming business. The study is based on an extensive interview program with oil skimming equipment manufacturers, and oil spill response companies. The model comprises of an external, and an internal analysis synthesized into a SWOT-matrix from which five strategic directions are extracted. These directions are described as well as their respective business impact on Sandvik Process Systems. Sandvik Process Systems’ skimmer is a steel belt skimmer developed in the 1960’s. With a lifting height of up to three meters and a width of up to 400 mm, the Sandvik oil skimmer is capable of lifting 354 liters per hour in optimal conditions. Compared to its competitors, the skimmer is a low cost alternative priced at 66-75% below industry average. However, the results of the analysis indicate a poor competitiveness of Sandvik Process Systems’ product. Due to an inferior technology, Sandvik Process Systems’ skimmer lacks the capacity needed to target the offshore market. Therefore, the product can only target the industrial market. Meanwhile, many competitors offer complete solution packages including as pumps, storage tanks, and a variety of specialized skimmers in order to increase their competitiveness.

Looking at the competitors it is clear that Sandvik Process Systems’ skimmer does have advantages. However, many of the advantages are based on organizational strengths which are difficult to leverage. Also, the organization does not have any experience from the oil skimming market and due to the small size of the market, it is doubtful if Sandvik Process Systems are able to devote the necessary resources to overcome this hurdle. Due to a revenue target set at EUR 2.33 million, Sandvik Process System’s skimmer would require a 23.9% of the market value or 119% of the number of skimmers sold.

Despite this thesis reaching the conclusion that Sandvik Process Systems should not enter the oil skimming market; it

also stipulates that Sandvik Process Systems does have the potential to successfully sell skimmers. However, reaching the goal of EUR 2.33 million is deemed unlikely. The mechanisms through which oil is removed from the water surface can be divided into oleophilic techniques, which rely on the adhesion of oil to a moving surface, and non-oleophilic techniques. Non-oleophilic techniques include weir skimmers relying on gravity, suction systems, and mechanical skimmers, which physically lift the oil with scoops, or grabs. Oleophilic skimmers recover oil based on the properties of specific materials, which have greater affinity for oil than for water. There exist numerous types of oleophilic skimmers and they are therefore divided into subgroups such as disc skimmers, drum skimmers, rope mop skimmers, belt skimmers, and brush skimmers. Regardless of the type of skimmer, the principle behind the technique used is the same for all oleophilic skimmers. The skimming head, i.e. the part with the oleophilic surface, is rotated or pulled through the oil slick and the oil is then scraped or squeezed off and the oil removed into a sump to be pumped or sucked away.

Oleophilic skimmers usually achieve the highest ratio of recovered oil in relation to entrained water, also referred to as the recovery efficiency, compared to other skimmer types. Oleophilic skimmers reach their highest efficiency when handling medium viscosity oils (between 100 – 2000 cSt). Diesel, kerosene and other low viscosity oil products generally do not adhere to the oleophilic surface in sufficiently thick layers to attain high recovery rates. Higher viscosity oils such as heavy bunker oil on the other hand, can prove to be difficult to remove due to its tendency to form large clumps in the water, which are too heavy and compact to be skimmed. Comparatively, oil-water emulsions can be almost impossible to recover with oleophilic skimmers, due to the fact that emulsions are nearly non-adhesive.

## V. DESIGN OF OIL SKIMMER

The design of the components used is based on the data available in the various design textbooks and reference books. This is the most important step in our project and hence, the design procedure was thoroughly verified. The dimensions were compared with the standard dimensions of the components available and the best feasible design was finalized.

### A. Motor

Motor was selected on basis of detailed research on application of the oil skimmer from various sources. The motors available in the market were thoroughly searched and information was gathered from vendors. There were motors having various speed rating ranging from 720 rpm to 1440



rpm. The selection was done taking into consideration the availability and cost of motor. Electric DC motor was ruled out due to time required for its availability from date of order.

The following specifications suited the project requirements:

Power rating: 0.5 HP (373 W)

Voltage supply: 415V 50Hz, 3 $\phi$

Speed: 1440 rpm

### B. Gearbox

On basis of comparison of different types of gearboxes, worm and worm type gearbox was selected. First, calculations were carried out on helical-spur and helical-helical combination. These two types of gearboxes were ruled out due to following reasons: The gear ratio of 1:70 would not be suitable for both helical and spur gears; The ideal use of spur and helical gears is for high power transmission. The dimensions thus acquired after final calculations led to bulky design of gear box. Hence taking into consideration the required output speed of shaft that is 30 rpm, gear ratio i.e. 48, we decided to design worm and worm type gear box for compact design and low weight.

Design calculations;

Gear ratio  $G = \text{Input speed/Output speed}$

$$= 1440/30$$

$$= 48$$

Material Selection: From manufacturer's catalogue,

I. Worm: EN 24  $S_{ut} = 850 \text{ N/mm}^2$ , 248 BHN

II. Worm Gear: Phosphor Bronze:  $S_{ut} = 245 \text{ N/mm}^2$ , 95 BHN

$$\tan \lambda = z_w/q$$

where,

$$z_w = \text{No. of starts on worm} = 1$$

$$q = \text{Diametrical quotient} = 10$$

$$\text{Therefore, } \lambda = \tan^{-1}(1/10)$$

$$= 5.7105 \text{ degrees}$$

$$G = z_g(\text{No. of teeth on gear})/z_w(\text{No. of starts on worm})$$

$$\text{Therefore, } z_g = 48$$

In worm gear pair, always worm gear governs the design.

Beam Strength of worm gear tooth:

$$F_b = \sigma_{bg} \cdot b \cdot m \cdot Y \cdot \cos \lambda$$

Where,

$F_b$  = Beam strength of worm gear tooth, N

$\sigma_{bg}$  = Permissible bending stress for worm gear,  $\text{N/mm}^2$

$b$  = Face width of worm gear, mm

$m$  = Transverse module, mm

$\lambda$  = Lead Angle of worm

$Y$  = Lewis Form factor for worm gear tooth

$$\sigma_{bg} = (S_{ut})/3$$

$$= 245/3$$

$$= 81.67 \text{ N/mm}^2$$

Where,  $S_{ut}$  = Ultimate Tensile strength of worm gear material

$$b = 0.75dw$$

$$d_w = mq$$

Therefore,  $b = 0.75m \cdot q$ .

$$= 0.75 \cdot m \cdot 10$$

$$= 7.5m \text{ mm}$$

For 20 degrees FDI,  $Y = [(0.484) - (2.87/z_g)]$

$$= 0.484 - (2.87/48)$$

$$= 0.4242$$

$$F_b = 81.67 \times 7.5m \times \cos(5.7105) \times 0.4242 \times m$$

$$= 258.57m^2 \text{ N}$$

Wear Strength of Worm gear tooth

$$F_w = d_g \cdot b \cdot K$$

Where,

$d_g$  = PCD of worm gear, mm

$K$  = Worm gear wear factor/Material combination factor,  $\text{N/mm}^2$

From Table 5.14.1, Design of Machine Elements II- R.B.Patil

For materials selected,  $\lambda < 10$  degrees,  $K = 0.52$

Therefore,  $d_g = m \cdot z_g$

$$= 50m$$

$$F_w = 7.5m \times 50m \times 0.52$$

$$= 197.76m^2 \text{ N}$$

As  $F_b > F_w$ , Worm gear is weaker in pitting.

Hence, it should be designed for safety against pitting failure.

Effective load on worm gear tooth

$$F_{eff} = [K_a \cdot (F_g)_t] / K_v$$

Where,

$F_{eff}$  = Effective load, N

$K_a$  = Application factor = 1

$K_v$  = Velocity factor =  $6 / (6 + v_g) = 6 / (6 + 0.07539m)$

$V_g = d_g \cdot n_g \cdot \pi / 60000 = (\pi \cdot m \cdot 48.30) / 60000 = 0.07539m \text{ m/s}$

$(F_g)_t$  = Tangential force acting on worm gear tooth =  $P / v_g = 4.955 \times (10^3) / m \text{ N}$

$$F_{eff} = [1 \times 4.955 \times (10^3)] / (6 / (6 + 0.07539m))$$

i. Estimation of module

In order to avoid pitting failure  $F_w = N_f \cdot F_{eff}$

$$197.76m^2 = 1.5 \times [1 \times 4.955 \times (10^3)] / (6 / (6 + 0.07539m))$$

Therefore,  $m = 3.39 = 4 \text{ mm}$  (Approx.)

Hence, the designation of worm gear pair:  $z_w / z_g / q / m = 1 / 48 / 10 / 4$

Dimensions of worm and worm gear:

Module ( $m$ ) = 4mm

$z_w = 1$ ,  $z_g = 48$

$d_w = 40 \text{ mm}$ ,  $d_g = 192 \text{ mm}$

Pitch ( $p_a$ ) = 12.56 mm

$L = 12.56 \text{ mm}$

$\lambda = 5.71 \text{ degrees}$

$b = 30 \text{ mm}$

Center distance ( $a$ ) = 116 mm

Addendum ( $h_a$ ) = 4mm Dedendum ( $h_f$ ) = 4.8mm

Length of worm ( $L_w$ ) = 68 mm

Force analysis:

$$(F_t)_w = P_i / V_w$$

$$= 373 / 3.015$$

$$= 123.71 \text{ N}$$

$$(F_t)_w = (F_g)_g = 123.71 \text{ N}$$

$$(F_g)_w = (F_t)_w / \tan(\phi_v + \lambda)$$

$$= 123.71 / \tan(1.4 + 5.71)$$

$$= 991.43 \text{ N}$$

$$(F_a)_w = (F_t)_g = 991.43 \text{ N}$$

$$(F_r)_w = (F_t)_w / \sin \lambda \times \tan \phi_n (\tan \lambda / \tan \phi_v)$$

$$= 123.71 / \sin 5.71 \times \tan 20 (\tan 5.71 / \tan 1.4)$$

$$= 1848.9 \text{ N}$$

Weight of worm and worm gear

Volume of worm ( $vol_w$ ) =  $\pi / 4 \cdot d_w^2 \cdot L_w$

$$= 8.54 \times (10^{-5}) \text{ m}^3$$

Mass = Density  $\times$  ( $vol$ )<sub>w</sub>

$$m = \rho \times v_w$$

$$= 8900 \text{ kg/m}^3$$

$$m = 8900 \times 8.54 \times (10^{-5})$$

$$= 0.7605 \text{ kg}$$

$$w_{(w)} = mg$$

$$= 0.7605 \times 9.81$$

$$= 7.46 \text{ N}$$

ii. Volume of worm gear

$(vol)_g = \pi / 4 \times (d_g)^2 \times b$

$$= 8.68 \times (10^{-4}) \text{ m}^3$$

Mass of worm gear

$$m = \rho(v)_g$$

$$= 7850 \text{ kg/(m}^3)$$

$$m = 7850 \times 8.68 \times (10^{-4})$$

Therefore,  $(m)_g = 0.681 \text{ kg}$

Weight of worm gear  $w = mg = 6.688 \text{ N}$

Vertical loading diagram & bending moment diagram:

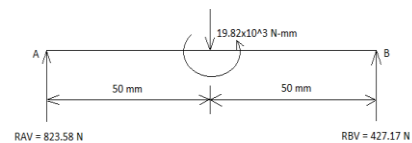

(a) Vertical Loading Diagram

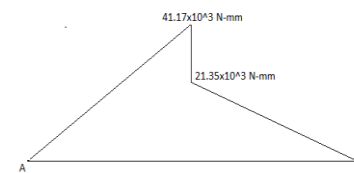

(b) Bending Moment Diagram

iii. Input shaft of gearbox:

1. Radial force at C  $(F_r)_w = 1243.29$

2. Weight of worm,  $W_w = 7.46 \text{ N}$

3. Moment by axial force=  $19.82 \times (10^3) \text{ Nmm}$

Horizontal loading diagram & bending moment diagram:

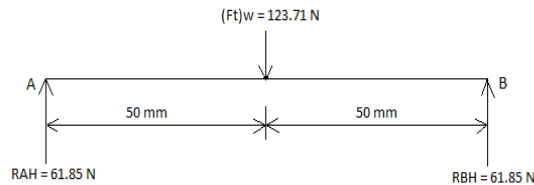

(a) Horizontal Loading Diagram

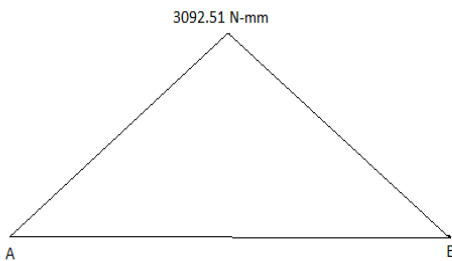

(b) Bending Moment Diagram

Taking moment about point A,

$$\sum MA = 0$$

$$7.46 \times 50 + 1243.29 \times 50 - 19.82 \times 10^3 - RB_V \times 100 + 0$$

Therefore,  $RB_V = 427.17\text{N}$

Now,  $\sum F_y = 0$

$$RA_V + RB_V - 7.46 - 1243.29 = 0$$

$$RA_V = 823.58\text{N}$$

Bending moment calculations,

$$MA_V = 0$$

$$(MC_V)L = RA_V \times 50 = 41.17 \times (10^3) \text{ Nmm}$$

$$(MC_V)R = RA_V \times 123 - 19.82 \times (10^3) = 21.35 \times (10^3)$$

$$MB_V = 0$$

Taking larger moment at C

$$MC_V = 41.17 \times (10^3) \text{ Nmm}$$

Forces in Horizontal load diagram

$$\text{Tangential Force } (F_t)_w = (F_t)_c = 123.71\text{N}$$

Taking moment at point A

$$\sum MA = 0$$

$$123.71 \times 50 - RB_H \times 100 = 0$$

$$RB_H = 61.85\text{N}$$

$$\sum F_Y = 0$$

$$RA_H + RB_H - 123.71 = 0$$

$$RA_H = 61.88\text{N}$$

Bending Moment calculations

$$MA_H = 0$$

$$MC_H = RA_H \times 50 = 3092.5 \text{ N-mm}$$

$$MB_H = 0$$

Resultant moment at point C

$$MC = [(MC_V)^2 + (MC_H)^2]^{(1/2)}$$

$$= 41.28 \times (10^3) \text{ N-mm}$$

Torque at point C

$$T = F_t \times d_w / 2$$

$$\text{Therefore, } T = 2.47 \times (10^3) \text{ N-mm}$$

For resolving shaft with sudden load and minor shock,

$$K_b = 1.5$$

$$K_t = 1$$

Equivalent torque 1

$$T_e = [(K_b M)^2 + (K_t T)^2]^{(1/2)}$$

$$\text{Therefore, } T_e = 61.96 \times (1063) \text{ N-mm}$$

Applying ASME code and considering keyway effect,

$$\begin{aligned} \tau_{(\text{permissible})} &= 0.75 \times 0.18 \times S_{ut} \\ &= 101.25 \text{ N/mm}^2 \end{aligned}$$

$$\begin{aligned} \tau_{(\text{permissible})} &= 0.75 \times 0.3 \times S_{yt} \\ &= 85.5 \text{ N/mm}^2 \end{aligned}$$

$$\tau_{(\text{max})} = 16T_e / \pi d^3$$

$$\text{Therefore, } d = 15\text{mm}$$

**Belt:**

The selection of belt was made on basis of study of belt type oil skimmer. The belt material is decided to be polyurethane belt. The different materials like steel, polyurethane, nylon were available. The polyurethane belt is easily available in the market. The dimensions of belt are decided on the amount of quantity of oil to be removed. The desired capacity is decided to be in the range of 2-4 lph. For this project work, following belt size has been decided:

Belt width  $b = 86\text{mm}$

Thickness of belt =  $1.4\text{mm}$

Full length of belt =  $1550\text{mm}$

Full length of belt =  $1550\text{mm}$

### Pulley:

The belt has to be properly aligned on rotating member i.e. pulley or drum. After analysis of Belt dimensions, the type of pulley was determined and clearance according to Indian standard were noted. According to Indian Standards,

Width of pulley  $B = 110\text{mm}$  (Including outer rims)

Outer Diameter of pulley =  $100\text{mm}$  (Ref. Manufacturer's catalogue & availability)

Belt width in mm	Width of pulley to be greater than belt by (mm)
Up to 125	13
125-150	25
250-375	38
475-500	50

Table 3.1 Width of Pulley

[Reference: Table No. 19.2, Page Number 719 Design of Machine Elements- R.S. Khurmi]

### Shaft:

Shaft was designed according to ASME codes. The standard pulley diameters were taken into account. The standard material used in domestic market was selected.

Assume shaft is made of steel material EN 19. The major reason of selection of EN 19 was because of its good ductility, shock resistance and its resistance to wear.

$$S_{ut} = 900 \text{ N/mm}^2$$

$$S_{yt} = 460 \text{ N/mm}^2$$

$$G = 80 \times 10^3 \text{ N/mm}^2$$

$$E = 200 \times 10^3 \text{ N/mm}^2$$

$$\mu = 0.40$$

$$\theta = 180 \text{ degrees}$$

Allowable Shear stress for shaft with keyway effect is

$$\begin{aligned} \tau_s &= 0.75 \times (0.18 S_{ut}) \\ &= 0.75 \times (0.18 \times 900) \\ &= 121.5 \text{ N/mm}^2 \end{aligned}$$

$$\begin{aligned} \tau_s &= 0.75 \times (0.3 S_{yt}) \\ &= 0.75 \times (0.3 \times 460) \\ &= 103.5 \text{ N/mm}^2 \end{aligned}$$

Torque

$$P = (2\pi NT) / 60000$$

$$373 = (2\pi \cdot 30 \cdot T) / 60000$$

$$T = 118.73 \times (10^3) \text{ N.mm}$$

Now,

$$F_1 / F_2 = e^{(\mu\theta)}$$

$$F_1 = 3.51 F_2$$

Where,

$F_1$  = Tension in tight side

$F_2$  = Tension in slack side

$$T = (F_1 - F_2) \times r_p$$

Where,

$r_p$  = Radius of pulley =  $50\text{mm}$

$$118.73 \times (10^3) = (2.19 F_2 - F_2) \times 50$$

Therefore,  $F_2 = 519.37 \text{ N}$

$$F_1 = 2491.21 \text{ N}$$

$$F = F_1 + F_2 = 3017.58 \text{ N}$$

Reaction at end supports:

$$R_A = R_B = (F/2)$$

Therefore,  $R_A = R_B = 1508.29 \text{ N}$

Bending moments

$$\sum M_A = 0$$

$$\sum M_B = 0$$

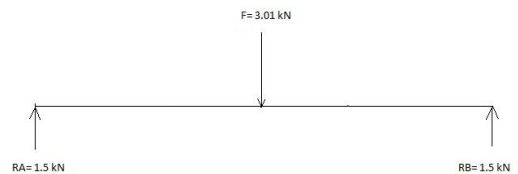

Loading Diagram of shaft

Length of shaft is  $400\text{mm}$

Max bending moment occurs at center point P.

$$M_P = R_A \times 200 = 241.40 \times (10^3) \text{ N.mm}$$

For revolving shaft of gradual loading,

$$k_b = 1.5, k_t = 1 \text{ [Ref. PSG design data book Pg. No. 7.21]}$$

Equivalent Torque ( $T_e$ )

$$T_e = \sqrt{[(k_b \cdot M_P)^2 + (k_t \cdot T)^2]}$$

$$T_e = 381.06 \times (10^3) \text{ N.mm}$$

Dia. Of shaft

$$\tau_{\max} = 16 T_e / \pi (d^3)$$



Therefore,  $d = 24 \text{ mm}$

**Design of key:**

We assume square key made up of same material as that of shaft

For sq. key,

$d = \text{Dia. Of shaft} = 24 \text{ mm}$

$l = \text{Length of hub} = 1.5d = 36 \text{ mm}$

$\tau_d = \text{Allowable shear stress, N/mm}^2$

$T = \text{Torque transmitted} = 118.73 \times (10^3) \text{ N.m}$

Direct shear stress induced in key is,

$\tau_d = 2T/dwl$

Therefore,  $w = 2 \text{ mm}$

For square key,  $h = w = 2 \text{ mm}$

**Bearing:**

From R.B.Patil Design of Machine Elements II, we selected the standard bearing from the calculated diameter of shaft.

From Table No. 4.14.2 Design of Machine Elements II, R.B.Patil,

For Conveyor applications,  $L_h = 8000 \text{ hrs}$

$L_{10} = L_h \cdot 10 \cdot n \cdot 60 / (10^6)$

$= 691.2 \text{ million revolutions}$

$L_{10} = [C/P_e]^a$

Where,  $P_e = X V F_t = 8547.34 \text{ N}$  ( $X = V = 1$  For machinery with no impact & self-aligning bearing).

From Table No. 4.15.1 Design of Machine Elements II, R.B.Patil

Diameter of shaft = 23mm

Bearing selected = 6204

Therefore, bearing selected is 6204. [Ref. Table 4.15.1 Design of Machine Elements II, R.B. Patil]

**VI. MODELING OF OIL SKIMMER PARTS USING CATIA SOFTWARE**

**PULLEY:**

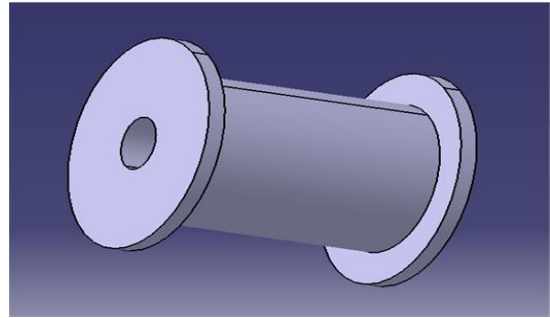

Fig 3.7.1 CATIA sketch of Pulley

**Shaft:**

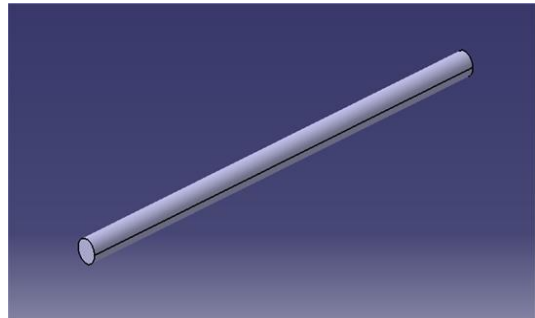

Fig 3.7.2 CATIA sketch of Shaft

**Bearing:**

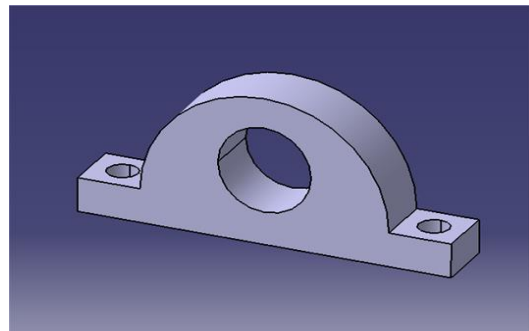

Fig 3.7.3 CATIA sketch of Bearing (With Bracket)

**Belt:**

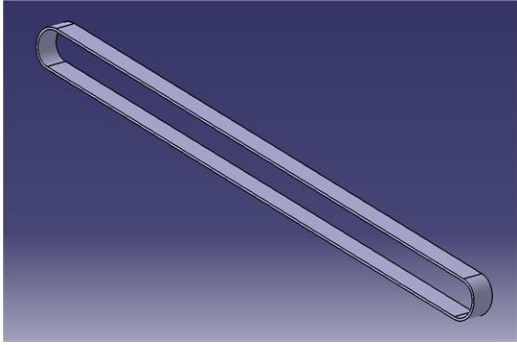

Fig 3.7.4 CATIA sketch of belt

**Tank:**

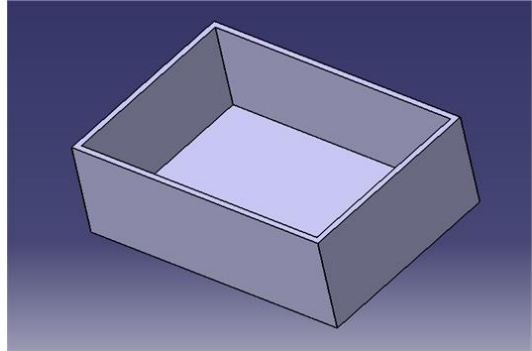

Fig 3.7.7 CATIA sketch of Tank

**Frame:**

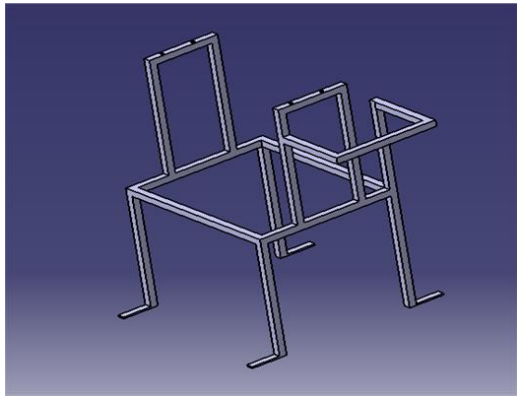

Fig 3.7.5 CATIA sketch of frame

**Nut & bolts:**

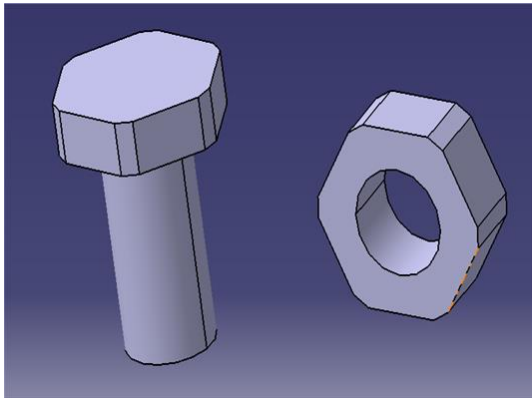

Fig 3.7.8 CATIA sketch of nut & bolt

**Scraper (Wiper):**

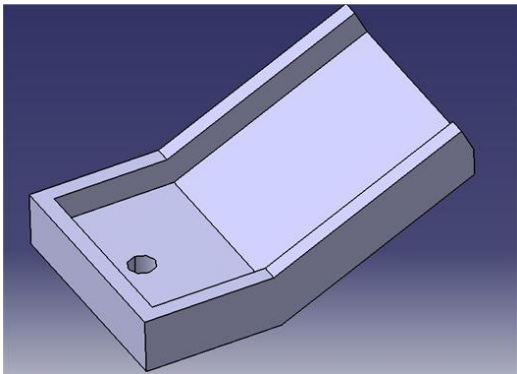

Fig 3.7.6 CATIA sketch of scraper

**Motor:**

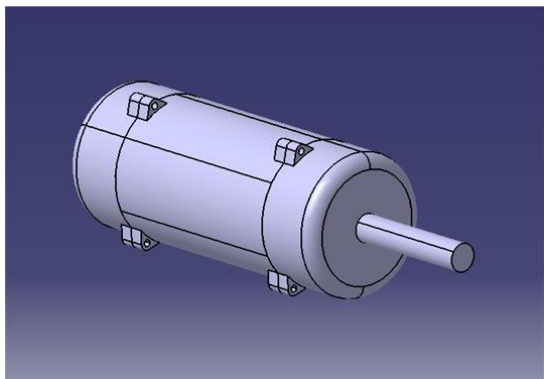

Fig 3.7.9 CATIA sketch of motor

**Assembly:**

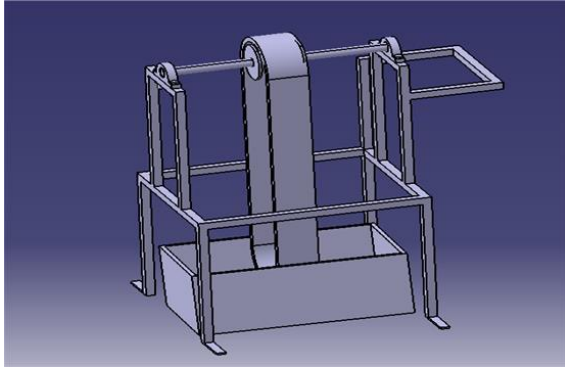

Fig 3.7.10 CATIA sketch of Assembly

**VII. CONCLUSION**

Hence, from the project we can conclude that we have successfully designed a compact, lightweight model of conventional belt type oil skimmer. In our attempt, detailed study and analysis was performed on drive unit including motor and gear box. The analysis and design of rotating member's viz. Shaft, pulley, coupling, belt is carried out. Care is taken that overall dimension of whole unit including tank become feasible and more compact. We conclude that our project runs on capacity of lph. This result is obtained by running the project in the laboratory and noting down the quantity of oil which is separated from oil-water mixture present in the tank.

Therefore, considering the present status of planet and pollution due to various sources, our project aims at overall reduction of water pollution in particular area. The wastage of oil can also be prevented by successful implementation of the project.

**REFERENCES**

[1]. Prof. Mamta Patel, (2013). "Design and Efficiency Comparison of Various Belt Type Oil Skimmers" International Journal of Science and Research (IJSR).

[2]. Sadek Z. Kassab "Empirical correlations for the performance of belt skimmer operating under environmental dynamic conditions" <http://www.academicjournals.org/IJWREE>

[3]. Arturo A. Keller and Kristin Clark, (2010). "Oil Recovery with Novel Skimmer Surfaces under Cold Climate Conditions"

[4]. Andrea AGRUSTA, Filippo Bianco, Luigi Perrella, Giuseppe Perrella, Igor Zotti, (2012). 'International Conference of Transport Science' presented a research paper named "Oil skimmers for coastal waters and open sea cleaning".

[5]. Anne Louise Brown, Michelle Mary Hanley and Nathaniel M. Stanton, (1993) "Surface Oil Skimmer- Sea Grant Depository" NHU T93001 C3, Senior design project, May 3, 1993.

[6]. Tushar Pathare, Mauli Zagade, Rohan Pawar, Priteshkumar Patil, Prof. A.S. Patil "Endless Belt Type Oil Skimmer" International Journal of Recent Research in Civil and Mechanical Engineering (IJRCME). [www.paperpublications.org](http://www.paperpublications.org).

[7]. Victoria Broje and Arturo A Keller, (2006) "Improved mechanical oil spill recovery using an optimized geometry for the skimmer surface" Donald Bren School of Environmental Science and Management, University of California, Santa Barbara, California 931065131.

[8]. Saara Hanninan and Juka Sassi- "Acute Oil Spills in Arctic Waters".

[9]. Peter Grill and Fredrik Linde "Oil Skimming Business Potential and Strategic Options Facing a Marginalised Business Segment at Sandvik Process Systems".

[10]. 'S.H. Schwartz', (2006) "Performance tests of four selected oil spill skimmers, in: Proceedings of the International Oil Spill Conference", American Petroleum Institute, Washington, DC, USA, 1979, pp. 493-496.

[11]. 'National Research Council', (2005) "Understanding oil spill dispersant and its effects", National Academic press, Washington.

[12]. R.B. Patil- Design of Machine Elements I, II Tech Max Publications, Pune.

[13]. R.S. Khurmi and J.K. Gupta, Machine Design-I S Chand Publications.

[14]. Design Data, P.S.G. College of Technology, Coimbatore, 2nd Edition. - 2009.

[15]. K Subramanya, Fluid Mechanics and Hydraulic machines, Tata McGraw Hill (2012)

[16]. 'F. X. Merlin, J. H. Anderson, "Improvement in at sea combating techniques over the last twenty years", Cen-tre de Droit et d'Economie de la Mer, Universit'e de Bretagne Occidentale CEDEM/UBO, 1998'.